

Main product features

- UPS for the Lightning Sensor & Analyzer
- Alarm relay interface via M12 8-pole connector, incl.
 - Lightning alarm relay
 - Power alarm relay
- Lightning alarm LED incl. support of alarm test / reset
- Status LED's
- Pass-through of Ethernet communication
- DIN rail mounted



The Jomitek Power and Interface Box, featuring support for multiple parallel power sources, including UPS via an externally accessible battery

Technical specification

Power supply input

AC (50/60Hz)	230VAC or 115VAC (factory configuration)
PoE input voltage range	24-48V
PoE Power Level Class	2 (17-20mA)
DC	24-48VDC

Power supply output

Via Ethernet Sensor port
PoE Class 2 (max. 6.5W)

Battery backup time

Assuming a single LSA >30 min

Alarm signal connector

M12, 8 pole

Protection class

IP55

Mounting

DIN rail

Ethernet in/out

RJ45 IP67

Relay output

Max. voltage / current 60V / 1A

Front panel features

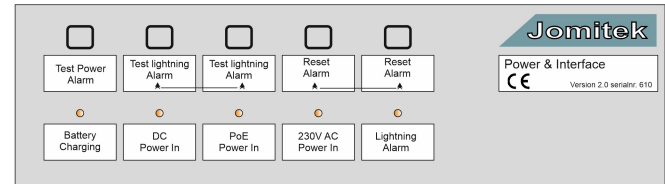

Front panel layout for the Power and Interface Box

General description

The Jomitek Lightning Sensor & Analyzer (LSA) make use of PoE (Power over Ethernet). Additionally, the LSA offer a direct relay output, to indicate a lightning strike, as an ordering option. This relay output use some of the Ethernet wires, making it a non-standard use of the Ethernet cable. The Power and Interface Box (PIB) ensures correct termination of the relay wires as well as providing UPS capability for the LSA.

Multiple parallel power options are supported as the supply may come from either 230/115VAC, 24-48VDC, PoE or the build-in battery. The PIB ensures continuous supply as long as at least one of the power sources provide power in their respective nominal voltage ranges.

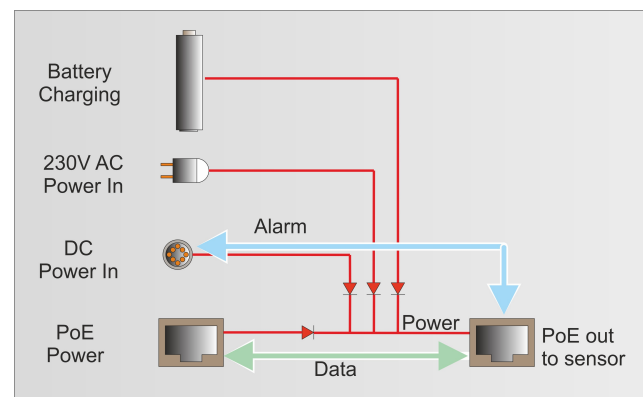

The integrated Lithium battery is rechargeable and may be swapped from outside the box.

The 4 green LEDs at the bottom left of the PIB front panel indicate the operational state of the 4 possible power input sources, with the last, bottom right, red LED signalling the lightning alarm relay output state. When lit, a lightning alarm is active.

The top row buttons allow for test of the power failure relay output (relay is active, when button is pushed in). Test of lightning alarm, by pressing both respective buttons continuously for 5 seconds, and reset of lightning alarm, by pressing both respective buttons continuously for 5 seconds.

Connector configuration

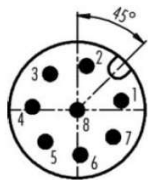

	X	Y
1	2,69	0,57
2	0,57	2,69
3	-1,66	2,20
4	-2,75	0,19
5	-1,94	-1,94
6	0,19	-2,74
7	2,20	-1,65
8	0,00	0,00

- 1 weiß/white
- 2 braun/brown
- 3 grün/green
- 4 gelb/yellow
- 5 grau/grey
- 6 rosa/pink
- 7 blau/blue
- 8 rot/red

Geschirmte Versionen: Schirm auf Gehäuse oder Pin 8
Shielded versions: shield on housing or pin 8

Standards

This device fulfils below standards:

EMC directive

- Emission: EN 50081-2:1993
- Immunity: EN 61000-6-2:2005

Low Voltage directive

- EN 61010-1:2010

International Protection Rating (IP Code)

- IP55 (dust protected, water jets)

Pin	Description
1	Power failure
2	Relay pin
3	Alarm reset (low)
4	Alarm reset (high)
5	Lightning alarm relay pin
6	Lightning Alarm relay pin
7	DC supply in +/-
8	DC supply in +/-
Shield	Earth / ground

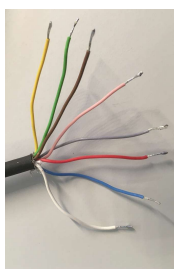

Electrical interface

All inputs and outputs are isolated by optocouplers.

Digital inputs:

- Reset alarm

Digital outputs:

- Lightning alarm
- Power alarm

Electrical interface, application example 1 (relay signals referencing shield):

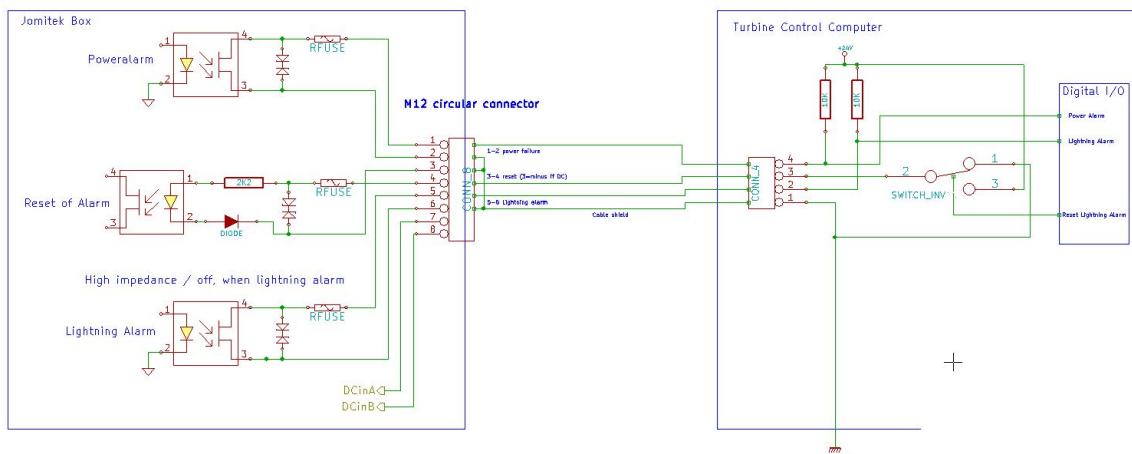

Electrical interface, application example 2 (isolated, including isolated shield):

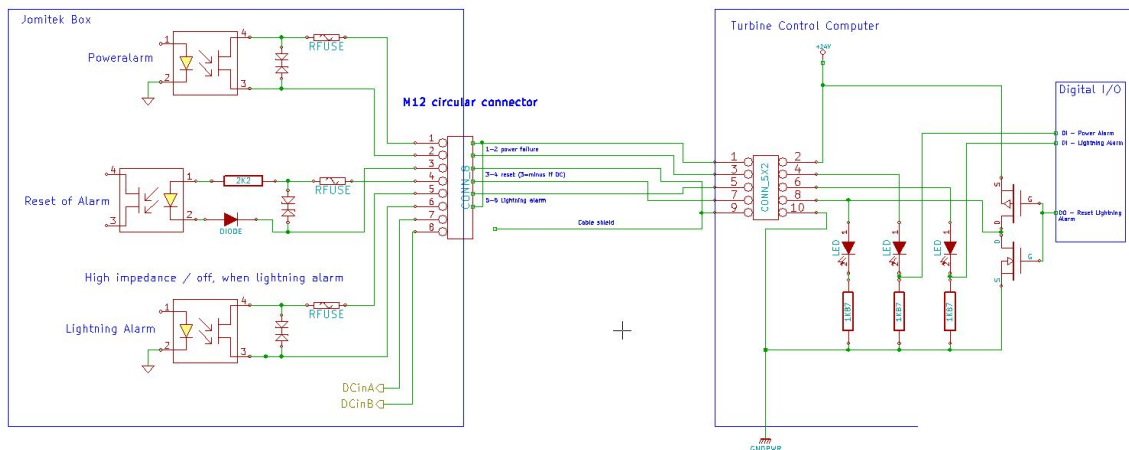

Mechanical dimensions and attachment

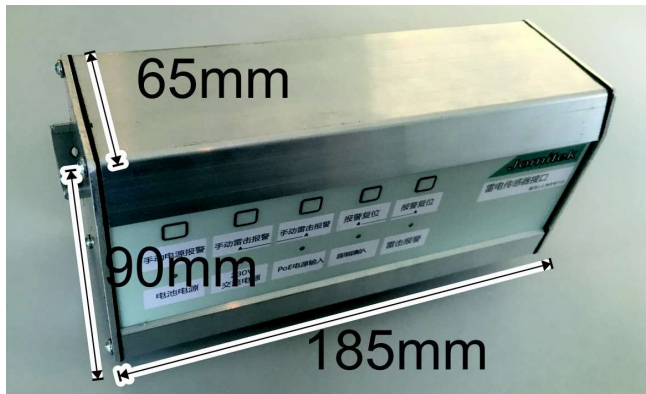

Height, width and length of the PIB



Backside of PIB, illustrating DIN rail fittings on a rail



Cable accessory, LSA-ETH-RJ45IP67-RJ45IP20



Cable accessory, M12-DC-POWER-RELAY

Connector cables

The AC power cable use the industry standard C13 format, and is by default open ended (no connector), at the other end of the cable, delivered with a length of 1m. Custom lengths on request. Jomitek product name reference, C13-AC-POWER

The Ethernet control cable, when used, is most often ordered with an IP20 RJ45 connector terminating to the control-side. Jomitek product name reference, LSA-ETH-RJ45IP67-RJ45IP20

The Ethernet sensor cable is either of two cable variants, depending on the connector used in the LSA, either M12 X-coded (default) or RJ45.

LSA-M12: Jomitek product name reference, LSA-ETH-M12-RJ45IP67

LSA-RJ45: Jomitek product name reference, LSA-ETH-RJ45IP67-RJ45IP67

The alarm signal connector use the Jomitek reference M12-DC-POWER-RELAY, and as the reference name implies it can serve multiple purposes, feeding DC power, clearing a lightning alarm and signal both power and lightning alarm relays, see the connector configuration description.

Ordering information:

Note that the Power and Interface Box does not include cable and external connector accessories. These should be ordered according to the specific connectivity targeted, and with cable lengths relevant for the installation.

Part numbers listed with 'xxx' should have the x's replaced with the requested cable length in decimeter, i.e. a 5m length is '050'.

Part number / Description incl. accessories

J310 00002 001
Power and Interface Box for the LSA

J710 00038 003
Cable kit with IEC C13 connector at one end, open ended at the other

J700 00048 xxx
Cable with RJ45 IP67 connector at one end, RJ45 IP20 at the other.

J700 00080 xxx
Cable with RJ45 IP67 connector at one end, M12 X-coded at the other.

J700 00037 xxx
Cable with RJ45 IP67 connector at both ends.

J740 00056 xxx
Cable kit with M12 connector at one end, open ended at the other